



## About SGC 120

The SGC 120 controller contains all the functions needed to protect and control the genset, the genset breaker, and also a mains breaker. The controller also has a deep sleep function. This function stops all normal controller functions when the genset is not in operation, which extends the battery life.

The values and alarms are shown on the LCD display screen and operators can control the system from the display.

The SGC 120 controller can measure the voltage and frequency for mains and gensets, and the electrical load (true RMS).

You can use the DEIF Smart connect software to configure the inputs and outputs. You can also configure the parameters on the controller.

## Display and language functions

Use the buttons on the controller to start and stop sequences, and change the running mode. You can also configure parameters from the display. The display is a full graphics LCD display and backlit.

The display views change automatically after an adjustable delay time. You can configure this delay time in the configuration menu.

The controller supports many different languages, for example, English, Chinese and Spanish.

## SGC 120 functions

### Monitor

You can use the SGC 120 to monitor:

- 1-phase, 2-phase, 3-phase, and split-phase voltage, frequency, load current, and power factor.
- Engine safety parameters. For example, the engine temperature, oil pressure and fuel level.
- Fuel theft protection
- The engine battery

### Control

Use the SGC 120 to control:

- Coolant temperature
- Idle speed
- Automatic fuel transfer

### Running modes

The SGC 120 controller has an AUTO mode and a manual mode.

### Operation modes

In AUTO mode, the controller supports these applications:

- Island
- Automatic mains failure (AMF)
- Remote start/stop
- Auto exercise
- Engine drive

You can also use the auto start/stop function in auto mode. Activate the digital start/stop input to start the engine. Deactivate the input to stop the engine.

### Battery charging alternator

The controller has an I/O interface for the battery charging alternator.

### Counters

- Engine starts
- Engine trips
- Engine running hours
- Genset and mains kWh, kVAh, kvarh
- Maintenance

### 2-level password protection

To protect against unauthorised changes.

### Event logs

The controller has an event log for 100 events with real-time clock stamps and engine running hours information. EEPROM is also available for extended event logs.

**Engine drive and island operation**

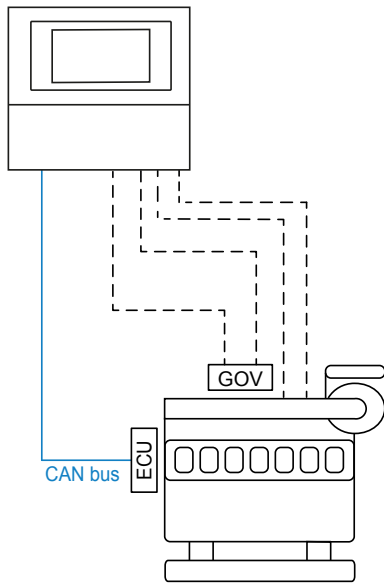

**Engine drive**

Use the SGC to control one engine. The controller has all the functions necessary to protect the engine.

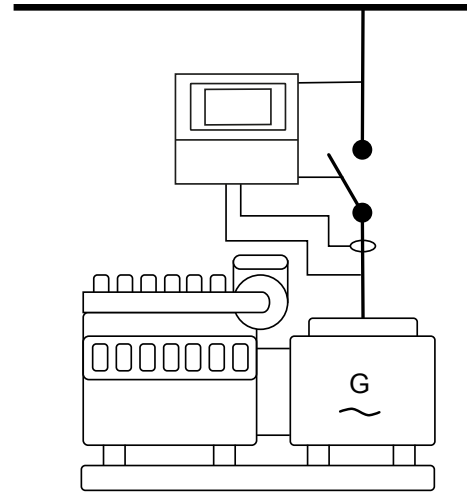

**Island**

Island mode is typically used in power plants that are isolated from other power generation systems.

**Automatic mains failure (AMF)**

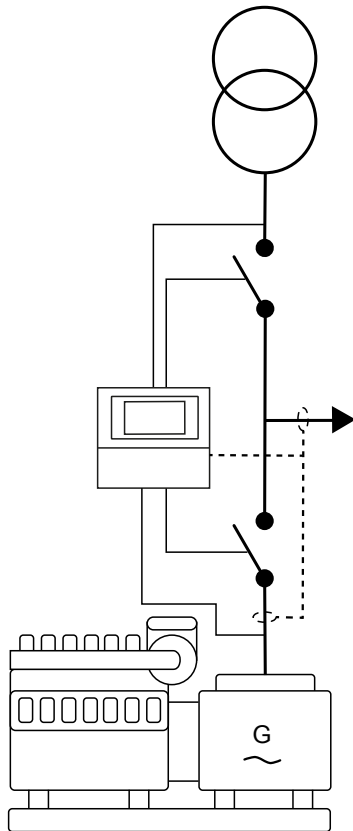

**Automatic mains failure (AMF)**

If there is a significant loss of mains power or a total blackout, the controller automatically changes the supply to the generator.

This makes sure that there is power during a mains failure and prevents damage to electrical equipment.

You can place the CT on the line from the genset or on the load side.

Typical wiring

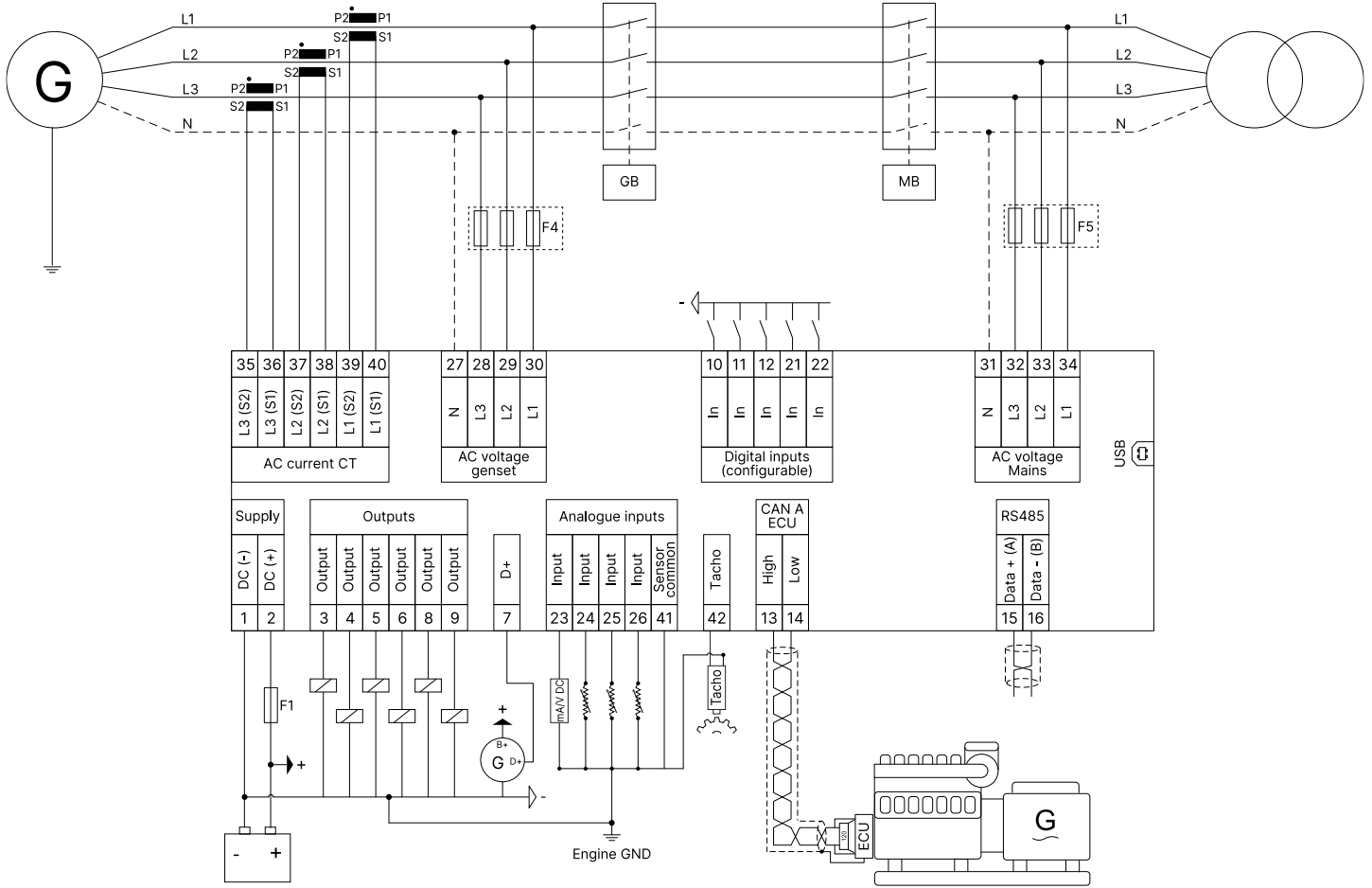

**NOTE** Refer to the **SGC 120 User's manual** for the grounding specifications.

Communication

- RS-485
- CAN bus for engine communication with support for Stage 5/Tier 4 Final
- USB

Approvals

- CE
- UL
- See [www.deif.com](http://www.deif.com) for the most recent approvals.

### Power supply

- Nominal voltage: 12/24 V DC
- Operating range: 8 to 32 V DC

### Inputs and outputs

- Digital inputs:
  - 5 x switch-to-ground. You can configure 4 switch-to-ground inputs through analogue inputs
  - Negative switching
  - Maximum input voltage: +32 V
  - Minimum input voltage: -24 V
  - Current source: 2.42 mA to 7.27 mA (depends on the battery voltage)
- Digital outputs: 6 x 0.5 A, configurable
- Analogue inputs:
  - 3 x resistive inputs, configurable
    - 2 x 10 to 1000  $\Omega$
    - 1 x 10 to 5000  $\Omega$
  - 1 x 4 to 20 mA

### Environment

- Operating temperature: -20 to +65 °C (-4 to +149 °F)
- Storage temperature: -30 to +75 °C (-22 to +167 °F)
- Humidity: 0 to 95 % RH
- Protection degree: IP65 in panel

### Measurements

#### Mains/genset voltage measurement

32 to 300 V AC RMS for phase-neutral, 32 to 520 V AC RMS for phase-phase, 5 to 75 Hz

#### Load current measurement

Nominal: -/5 A for current transformer (CT) secondary

#### Magnetic pickup measurement

0.2 to 45 V RMS, 10 Hz to 10 kHz

### Dimensions

Dimensions: 139.0 mm x 114.0 mm x 38.3 mm

Panel cut-out: 118.0 mm x 93.0 mm

### Protections

1 x Reverse power.....	ANSI 32R
1 x Over-current.....	ANSI 50TD
3 x Over-voltage.....	ANSI 59
3 x Under-voltage.....	ANSI 27P
3 x Over-frequency.....	ANSI 81O
3 x Under-frequency.....	ANSI 81U
1 x Overload.....	ANSI 32F
1 x Under-speed.....	ANSI 14
1 x Overspeed.....	ANSI 12
1 x Unbalanced load	
1 x Low load	
2 x Phase reversal detection	
1 x Configurable crank connect	
1 x Battery monitoring	
1 x Charging alternator	
1 x Pre-heat	
1 x Coolant temperature	
1 x Lube oil pressure	
1 x Fuel level	
1 x Fuel theft	
1 x ECU communication failure	
1 x ECU diagnostic lamps	

#### For more information:

DEIF A/S

Frisenborgvej 33, 7800 Skive, Denmark

Tel.: +45 9614 9614, info@deif.com

www.deif.com

