



## About SGC 420

The SGC 420 controller contains all the functions needed to protect and control the genset, the genset breaker, and also a mains breaker. The controller also has deep sleep function. This function stops all normal controller functions when the genset is not in operation, which extends the battery life.

The values and alarms are shown on the LCD display screen and operators can control the system from the display.

The SGC 420 controller can monitor the site battery and significantly reduce your fuel consumption. The controller can also be used to monitor the shelter temperature, engine and alternator parameters, and the true RMS voltage and current.

You can use the DEIF Smart connect software to configure the inputs and outputs. You can also configure the parameters on the controller.

## Display and language functions

### Display and language

Use the buttons on the controller to control the genset breaker and the mains breaker. There is also a button to stop alarms. You can also configure parameters from the display. The display is a full graphics LCD display and backlit.

The controller supports many language, for example, English, Chinese and Spanish.

### Password protection and event logs

The controller has two password levels that you can configure on the controller.

The controller has an event log for 100 events with real-time clock stamps and engine running hours information. EEPROM is also available for extended event logs.

## SGC 420 functions

### Monitor

You can use the SGC 420 to monitor:

- 1-phase, 2-phase, 3-phase, and split-phase voltage, frequency, load current, and power factor.
- Engine safety parameters. For example, engine temperature, oil pressure and fuel level.
- Site battery
- Shelter temperature
- Fuel theft protection

### Control

Use the SGC 420 to control:

- Coolant temperature
- Idle speed
- Auto fuel transfer
- Genset and mains breaker
- Fuel relay and crank

### Running modes

The SGC 420 controller has an auto mode and a manual mode. The controller also has a test mode.

You can use the night restriction function in auto and manual mode. When you use the night time function, the genset does not operate for an adjustable time interval.

### Operation modes

In auto mode, the controller supports these applications:

- Site battery and shelter temperature monitoring
- Automatic mains failure (AMF)
- Cyclic
- Remote start/stop
- Auto exercise
- Engine drive

You can also use the auto start/stop function in auto mode. Activate the digital start/stop input to start the engine. Deactivate the input to stop the engine.

### Battery charging alternator

The controller has an I/O interface for the alternator that charges the battery.

### Counters

- Engine start
- Engine trips
- Engine running hours
- Genset and mains kWh, kVAh, kvarh
- Maintenance

**Engine drive and island**

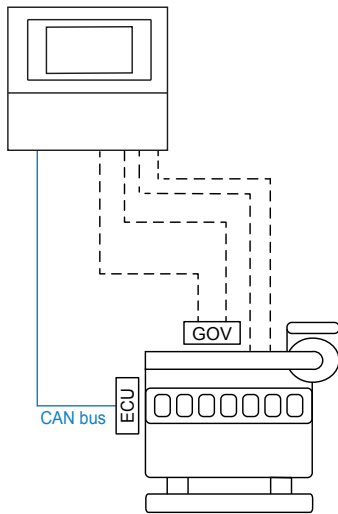

**Engine drive**

Use the SGC to control one engine. The controller has all the functions necessary to protect the engine.

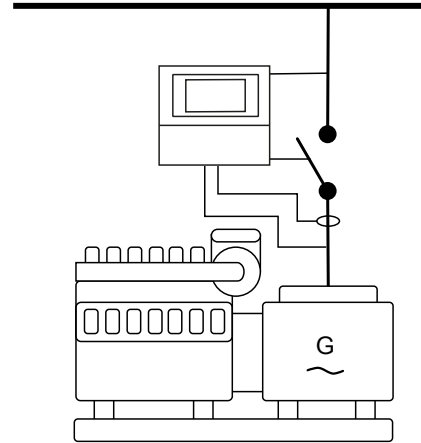

**Island**

Island mode is typically used in power plants that are isolated from other power generation systems.

**Automatic mains failure (AMF) and site battery monitoring**

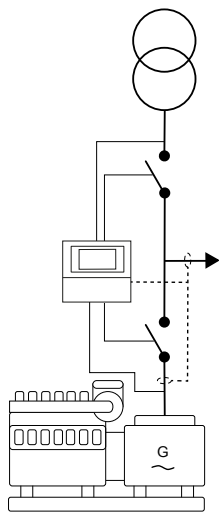

**AMF**

If there is a significant loss of mains power or a total blackout, the controller automatically changes the supply to the generator\*.

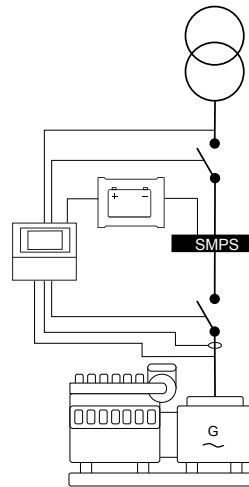

**Site battery**

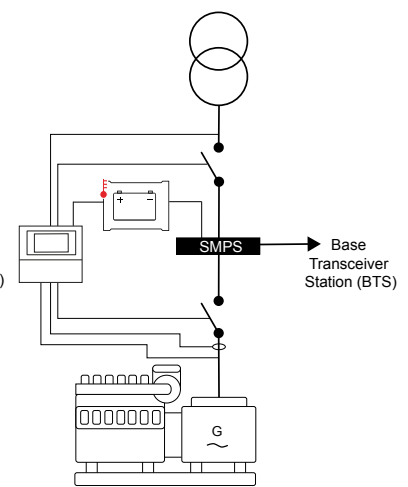

**Shelter temperature**

**Site battery monitoring**

The controller can monitor the site battery and the shelter temperature. The controller can control the battery charge and make sure the battery is sufficiently charged.

**NOTE** \* You can place the CT on the line from the genset or on the load side.

Typical wiring

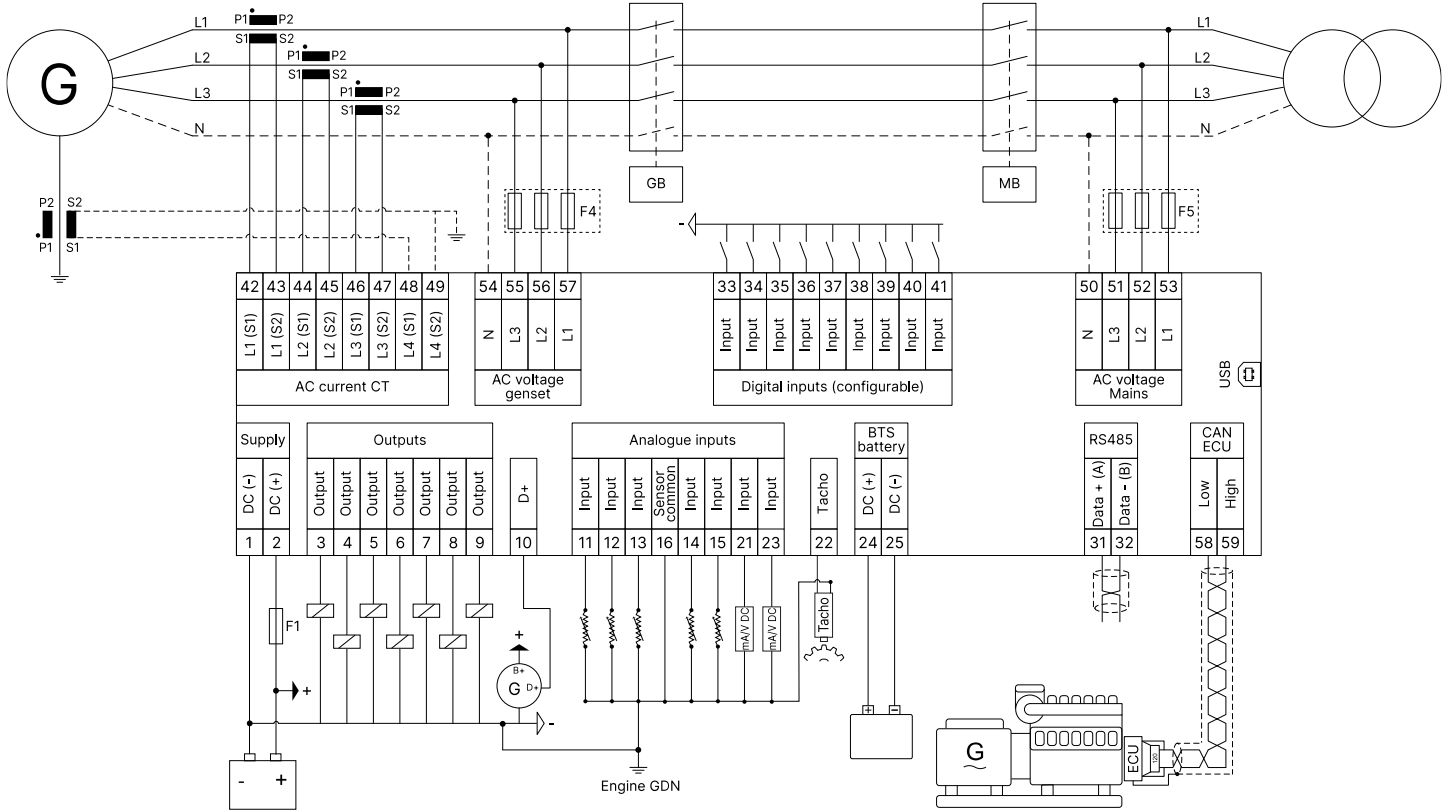

**NOTE** Refer to the **SGC 420 User manual** for the grounding specifications.

Communication

- Modbus RS-485
- CAN bus for engine communication
- USB interface to PC

Approvals

- CE
- UL



**More information**

See [www.deif.com](http://www.deif.com) for the newest approvals

## Technical specifications

### Power supply

- Nominal voltage: 12/24 V DC
- Operating range: 8 to 32 V DC

### Environment

- Operating temperature: -20 to +65 °C (-4 to +149 °F)
- Storage temperature: -30 to +75 °C (-22 to +167 °F)
- Humidity: 0 to 95 % RH
- Protection degree: IP65 in panel
- EMI/EMC: IEC 61000-6-2,4

### Inputs and outputs

- Digital inputs:
  - 9 x switch-to-ground. You can configure 7 switch-to-ground inputs through analogue inputs
  - Negative switching
  - Maximum input voltage: +32 V
  - Minimum input voltage: -24 V
  - Current source: 5 mA
- Digital outputs:
  - 5 x 1 A, configurable
  - 2 x 5 A, configurable
- Analogue inputs:
  - 5 x resistive inputs (10 to 5000 Ω), configurable
  - 2 x 4 to 20 mA/ 0 to 5 V input
  - 1 x differential input ( $\pm$  60 V DC)

### Measurements

#### Mains/genset voltage measurements

32 to 300 V AC RMS for phase-neutral, 32 to 520 V AC RMS for phase-phase, 5 to 75 Hz

#### Load current measurements

- Nominal: -/5 A for current transformer (CT) secondary
- 4 CT inputs

#### Magnetic pickup measurements

0.2 to 45 V AC RMS, 10 Hz to 10 kHz

### Dimensions

Dimensions: 233.0 mm x 173.0 mm x 38.5 mm

Panel cut-out: 219.0 mm x 158.0 mm

### Protections

1 x Reverse power.....	ANSI 32R
1 x Over-current.....	ANSI 50TD
3 x Over-voltage.....	ANSI 59
3 x Under-voltage.....	ANSI 27P
3 x Over-frequency.....	ANSI 81O
3 x Under-frequency.....	ANSI 81U
1 x Overload.....	ANSI 32F
1 x Under-speed.....	ANSI 14
1 x Overspeed.....	ANSI 12
1 x Unbalanced load	
1 x Low load	
2 x Phase reversal detection	
1 x Earth leakage/Fan current	
1 x Configurable crank connect	
1 x Battery monitoring	
1 x Charging alternator	
1 x Pre-heat	
1 x Coolant temperature	
1 x Lube oil pressure	
1 x Fuel level	
1 x Fuel theft	
1 x ECU communication failure	
1 x ECU diagnostic lamps	
1 x Site battery	
1 x Shelter temperature	

#### For more information:

DEIF A/S

Frisenborgvej 33, 7800 Skive, Denmark

Tel.: +45 9614 9614, info@deif.com

www.deif.com

